



SINCE 1884

# TIMPTE “B TRAIN”



From any angle the TimpTe “B Train” combines form and function. Smooth aerodynamic double wall aluminum sidewall cuts cleanly through the wind with its fuel efficient design. This sidewall design was pioneered by TimpTe in the 1960's. Two rows of L.E.D. side marker lamps are standard.



- Numerous options
- Local Parts & Service Support
- Aerodynamic Smooth Double Wall
- #1 Selling Grain Hopper in No. America
- 3 Year Limited Warranty
- Lightweight Aluminum Construction

[www.timpTe.com](http://www.timpTe.com)



Timpte "B Train" is standard with a 15 degree slope on the rear of the lead and the front of the pup. The tri-axle sub frame is designed to be clean, light weight, but not light duty. The sub frame is designed to handle the rigors of the Canadian weather and is coated with "Black Armor" to protect from corrosive elements.



Timpte hopper tubs are made of formed aluminum sheets. Design allows product to flow freely. Rubber flaps eliminate any potential water intrusion. All Timpte trailers are standard with liquid filled air scale gauge and dump valve in a weatherproof box.



- All Timpte hoppers are standard with easy access ladders, platforms, and grab handles. The originator of the "Flip Down" Rear ladder makes rear access effortless.
- Nose panels are thicker .063" aluminum in lieu of thinner panels on competitor's models.

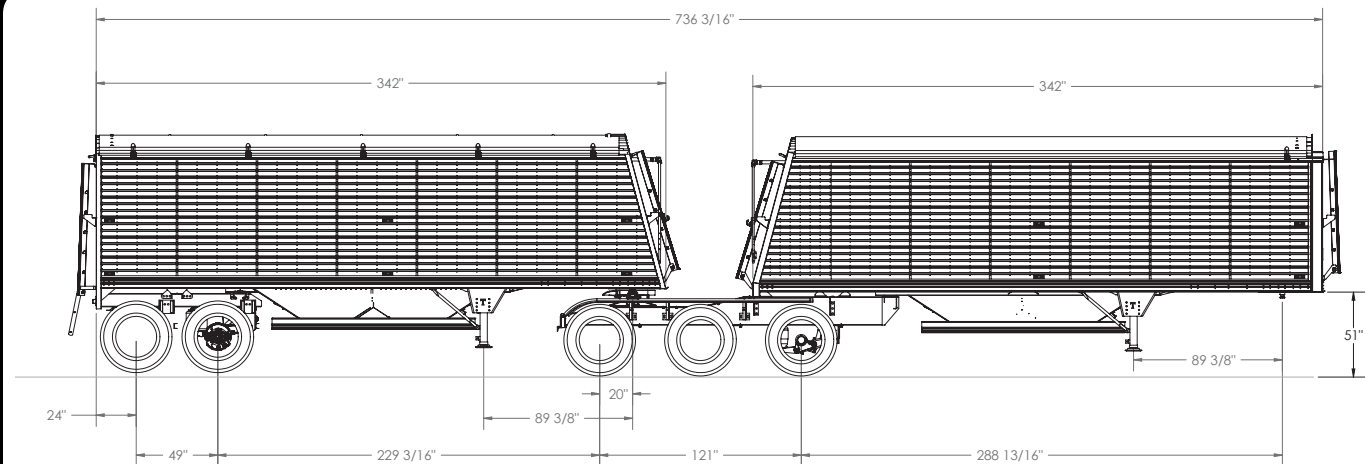

### STANDARD SPECIFICATIONS B-TRAIN PUP UNIT — 28'6" TANDEM AXLE (28'6" Overall Length)

- KINGPIN SETTING:** 20"
- WALL PANELS :** Pre-painted white .048" and .063" aluminum, corrugated on 4" centers.
- ACCESS:** Aluminum ladders, handholds, and platforms front and rear.
- FRONT CORNERS:** 3" x 4" rectangular tube, mill finish aluminum
- NOSE ASSEMBLY:** Extruded mill finish aluminum construction. 15 degree rearward slant.
- LIGHTS & WIRING:** CMVSS-108 w/weather-pack automotive style connections w/L.E.D. lights
- SUPPORT LEGS:** 50,000 lbs. lift capacity with roadside removable crank, low-profile shoe.
- HOPPERS:** Two piece .125" aluminum formed tubs with 35.8 degree side slopes and 33 degree end slopes. Single tub design. Both hopper doors open from the center out. End slope panels-.080" aluminum supported by aluminum channel with Z shaped member. Divider Panel - .080 aluminum. 30"W x 22"L Hopper clearance 25".
- TRAPS:** 23,000 lb. rated air ride suspension 5" diameter axle with 10'1" total axle spread. Center axle is equal distance from front and rear axles.
- SUSPENSION & AXLES:** 16-1/2" X 7" complying with CMVSS 121. Meritor/Wabco 4 sensor, 2 modulator which exceeds the minimum requirements of CMVSS 121, S5.5.
- BRAKES:** Eight (8) 24.5 x 8.25 white steel disc painted, hub piloted.
- WHEELS:** Eight (8) 11R24.5 Bridgestone R195F radials.
- TIRES:** 18 oz. roll tarp with front mounted crank.
- TARP:** Five (5) - 9" rise galvanized steel arch type.
- TARP BOWS:** Black protective metal coating on all steel parts.
- PAINT:** Black protective metal coating on all steel parts.

#### NOTES:

All Dimensions are ± or -1/4". All Specification subject to change Timpte reserves the right to change design specifications with out notice contained herein is general in nature and is not intended for specific applications.

**WARRANTY:** See Timpte Warranty Card

### STANDARD SPECIFICATIONS B-TRAIN LEAD UNIT — 38' TRIAXLE (28'6" Hopper Body Assembly – 38' Overall length)

- KINGPIN SETTING:** 24"
- WALL PANELS:** Pre-painted white .048" and .063" aluminum, corrugated on 4" centers.
- ACCESS:** Aluminum ladders, handholds, and platforms front and rear
- FRONT CORNERS:** 6" radius, mill finish aluminum (color optional).
- LIGHTS & WIRING:** CMVSS-108 w/weather-pack automotive style connections w/L.E.D. lights
- SUPPORT LEGS:** 50,000 lb. lift capacity with roadside removable crank, low-profile shoe.
- HOPPERS:** Two piece .125" aluminum formed tubs with 35.8 degree side slope angle and 33 degree end slope angle. Single tub design. Both doors open from the center out. End slope panels-.080" aluminum supported by aluminum channel with Za shaped member, 33 degree slope angle. Divider Panel - .080 aluminum.
- TRAPS:** 30"W x 22"L Hopper clearance 25".
- SUSPENSION & AXLES:** 23,000 lb. rated air ride suspension 5" diameter axle with 49" axle spacing lead.
- BRAKES:** 16-1/2" X 7" complying with CMVSS 121. Meritor/Wabco 4 sensor, 2 modulator which exceeds the minimum requirements of CMVSS 121, S5.5.
- WHEELS:** Twelve (12) 24.5 x 8.25 white steel disc painted, hub piloted.
- TIRES:** Twelve (12) 11R24.5 Bridgestone R195F radials.
- TARP:** 18 oz. roll tarp with rear mounted crank.
- TARP BOWS:** Five (5) - 9" rise galvanized steel arch type.
- PAINT:** Black protective metal coating on all steel parts.
- REAR FRAME:** Stainless steel and aluminum construction. 15 degree forward slant.
- FIFTH WHEEL:** Holland FW7040 Kompensator. W/progressive grease manifold.



SERVING THE TRANSPORTATION INDUSTRY SINCE 1884

Contact your nearest Canadian  
Authorized Timpte Dealer or:  
Timpte Industries  
1827 Industrial Drive  
David City, Nebraska, 68632 U.S.A.  
(402)-367-3056  
sales@timpte.com  
www.timpte.com